

KIEN6000 Industrial Ethernet Switch User's Manual

KYLAND Telecom Technology Co., Ltd.

KIEN6000 Industrial Ethernet Switch

User's Manual

Copyright © 2005 KYLAND Telecom Technology Co., Ltd.

All rights reserved.

No part of this documentation may be excerpted, reproduced, translated, annotated or duplicated, in any form or by any means without the prior written permission of KYLAND Corporation.

Publisher: **KYLAND Telecom Technology CO., LTD**

Address: 5/F, Office Building, Transport Center, East of Xisanqi Bridge
Haidian District, Beijing, China

Website: <http://www.kyland.com.cn>

Postcode: 100096

Tel: (+86 10) 82900770

Fax: (+86 10) 82900780

E-mail : marketing@kyland.com.cn

Version: V1, Dec. 2005

No.: e6t02050701

Preface

KIEN6000 is a high-performance network-managed industrial Ethernet switch specially designed by KYLAND Telecom Technology CO., LTD. for industrial applications. Its high-performance switch engine, solid and closed case design, high-efficient single-rib shape case heat dispersion surface without fans, overcurrent, overvoltage and EMC protection at power input side, and excellent EMC protection of RJ45 port allows KIEN6000 applicable in harsh and dangerous industrial environments. The redundant function of optical fiber network, independent entire network management channel, redundant power input function, and powerful entire network real-time management system provides multiplex guarantee for reliable operation of the system.

The User's Manual for KIEN6000 Industrial Ethernet Switch mainly introduces the information on technical principles, performance indexes, installation and commissioning, network management etc. to provide users with references in startup, expansion and routine maintenance. It is a practical teaching material that can be used by users in trainings and helps the relevant technical personnel to increase their knowledge and understanding of KIEN6000 industrial Ethernet switch.

This manual mainly includes the following contents:

Chapter 1 introduces general description and system features of KIEN6000 industrial Ethernet switch;

Chapter 2 introduces performance indexes and service functions of KIEN6000 industrial Ethernet switch;

Chapter 3 introduces hardware structure of KIEN6000 industrial Ethernet switch;

Chapter 4 introduces mounting process of KIEN6000 industrial Ethernet switch;

Chapter 5 introduces network management of KIEN6000 industrial Ethernet switch;

Chapter 6 introduces local management of KIEN6000 industrial Ethernet switch;

Chapter 7 introduces field test methods for KIEN6000 industrial Ethernet switch;

Chapter 8 introduces network-forming modes and system configuration of KIEN6000

industrial Ethernet switch;

Appendix A introduces twisted pair and pin distribution rules of KIEN6000 industrial Ethernet switch;

Appendix B introduces cable types and specifications of KIEN6000 industrial Ethernet switch;

Appendix C introduces abbreviations used in this manual.

Statement: as product and technology upgrades and improves constantly, the contents of this document may not completely accord with the actual product. For product upgrading information, please access our company's website or directly contact with our company's business representative.

Notice for Safety Operation

This product offers reliable performances as long as it is used within the designed scope. Artificial damage or destruction of the equipment should be avoided.

- Carefully read this manual and well preserve this manual for future reference;
- Do not place the equipments near water sources or damp places;
- Do not place anything on power cable which should be placed in unreachable places;
- Do not tie or wrap the cable to prevent fire.
- Power connectors and connectors for other equipments should be firmly interconnected and frequently checked.

In the following cases, please immediately disconnect the power supply and contact with our company:

1. Water gets into the equipments;
 2. Equipment damage or shell breakage;
 3. Abnormal operation conditions of equipment or the demonstrated performances have changed;
 4. The equipment emits odor, smoke or noise.
- Please keep optical fiber plugs and sockets clean. During operation of equipments, do not stare directly into the cross section of optical fiber;
 - Please keep the equipment clean; if necessary, wipe the equipment with soft cotton cloth;
 - Do not repair the equipment by yourself, unless it is clearly specified in the manual.

Explanation of Warning Marks:

This manual uses two kinds of noticeable warning signs to arouse special attention of users during operation. The implications of these signs are as follows:



Warning: pay special attention to the notes behind the mark, improper operation will result in serious damage of the switch or injury of operation personnel.



Caution, attention, warning, danger: remind the positions requiring attention during operation.

Contents

Chapter 1 System Overview	3
1.1 Product Overview.....	3
1.2 Features	3
1.3 Packing list and unpacking check	4
Chapter 2 Performance Indexes	6
2.1 System indexes	6
2.2 Service Interface	7
2.3 Service function	8
Chapter 3 Hardware Structure	10
3.1 System structure.....	10
3.2 Switch Structure.....	10
3.2.1 Case	10
3.2.2 Front panel	12
3.2.3 Top panel	15
3.2.4 Bottom panel.....	19
Chapter 4 Hardware Mounting	21
4.1 Mounting requirements	21
4.2 Main unit mounting	22
4.2.1 Rail mounting	22
4.2.2 Wall-mounting	23
4.3 Cable connection	26
4.4 Optical fiber connection	27
4.5 Cable wiring	28
Chapter 5 Testing Method	30
5.1 Self-testing process	30
5.2 Testing of Ethernet interface	30
5.3 Testing of optical fiber interface	31

Chapter 6 Networking Mode and System Configuration	32
6.1 Networking mode	32
6.2 System configuration	35
Appendix A Twisted-pair and Pin Distribution	36
Appendix B Cable Type and Specifications	39
Appendix C Glossary	40

Chapter 1 System Overview

1.1 Product Overview

KIEN6000 is a high-performance managed industrial Ethernet switch specially designed by KYLAND Telecom Technology CO., LTD. for industrial applications. Its high-performance exchange engine, solid and closed case design, high-efficient single-rib shape case heat dispersion surface without fans, overcurrent, overvoltage and EMC protection at power input side, and excellent EMC protection of RJ45 port allows KIEN6000 applicable in harsh and dangerous industrial environments. The redundant function of optical fiber network, independent full network management channel, redundant power input function, and powerful full network real-time management system provides multiplex guarantee for reliable operation of the system.

KIEN6000 industrial Ethernet switch provides two mounting ways, DIN rail and wall-mounting. On the front panel, there are two pairs of uplink redundant 100Base-FX single mode or multi-mode optical fiber interfaces. The uplink optical fiber interfaces can be used to form an optical fiber redundant ring network. In the event of system failure, the recovery time of the redundant ring network should be less than 300ms. The uplink Ethernet RJ45 interface can be used to form a twisted-pair redundant double ring network. It provides four 10Base-T/100Base-TX RJ45 ports. Each RJ45 port has adaptive function, capable of automatically configuring to 10Base-T or 100Base-TX status and full duplex or half duplex operation mode.

1.2 Features

High-performance Industrial Ethernet Switch

1. 10/100Base-T/TX Ethernet ports, adaptive, full/half duplex, auto MDI/MDI-X connection
2. 100Base-FX fiber ports, single mode/multimode, full duplex
3. High speed redundant ring with recovery time < 300ms



4. Supports VLAN to control broadcasting domain and segment flow.
5. Alarm relay output power supply and port link.
6. Broadcast storm control

Powerful Management Function

1. Integral management platform for the entire network can be done in WEB Brower and via Telnet.
2. Individual naming for each device in the network.
3. Setting and query of VLAN.
4. Setting and query for alarm of power and ports link.
5. Setting and query for port working mode, prioritization, and rate

Industrial Power

1. Industrial power input of DC24V (DC18V ~ 36V) .
2. Reliable protection for EMC and against over-current/over-voltage.
3. Redundant power input.

Rugged Design

1. Ribbed heat-removal design (fanless); operation at -35°C to +75°C
2. Solid IP40 housing
3. Easy DIN-Rail mounting or optional wall-mounting

1.3 Packing list and unpacking check

1. Packing list

The packing case includes the following items:

KIEN6000	1 unit
3-core DC power terminal	2 pieces
2-core alarming output terminal	1 piece



User's Manual for KIEN6000 Industrial Ethernet Switch	1 copy
Customer Service Guideline	1 copy
Φ3 grounding cold pressed terminal, M3×8 grounding screw	1 piece each

2. Unpacking check

Before opening the case, place it stably, pay attention to the direction of the packing case, and ensure its right side is facing upward, so as to prevent KIEN6000 from falling apart after opening the case. If a hard object is used to unclench the case, do not overly extend the hard object into the case to avoid damage of the equipments inside the case.

After opening the case, check the amount of KIEN6000 equipments (including main unit of KIEN6000, parts of equipment, user's manual, customer service guideline) according to the packing list, and check the appearance quality of KIEN6000.



Warning:

For the built-in precise parts of equipments, please handle with care and avoid strenuous vibration to avoid affecting the performances of equipments.

Chapter 2 Performance Indexes

2.1 System indexes

The system performance indexes of KIEN6000 industrial Ethernet switch are shown in Table 2-1.

Table 2-1 System Indexes

System Indexes	KIEN6000
Quantity of RJ45 port	4 ×10Base-T/100Base-TX
Quantity of uplink redundant RJ45 port	2 ×10Base-T/100Base-TX
Quantity of uplink redundant fiber port	2 x 100Base-FX-SM/MM
System parameters	Supporting standard: IEEE802.3, IEEE 802.3x, IEEE 802.3u, IEEE 802.1p, IEEE 802.1Q Store-and-Forward speed: 148810 pps Max. filtering speed: 148810 pps Switching mode: Store-and-Forward Switching bandwidth of system: 5.6G Mac address list: 8K Max. VLAN quantity: 4094 Electromagnetic compatibility interference: EN55022 Electromagnetic compatibility immunity: EN50082-2
Ethernet port	Physical port: shielded RJ-45 RJ-45 port: 10Base-T/100Base-TX, supporting automatic negotiation function Port standard: in line with IEEE802.3 standard Transmission distance: <100m
Fiber port	Optical power: >-13dbm(SM) >-20dbm(MM) Receiving sensitivity: <-28dbm(SM) <-35dbm(MM) Wave length: 1310nm(SM) 1550nm(SM) 1310 nm(MM) Transmission distance: 20 ~ 80Km(SM) <2Km(MM) Connector type: SC/FC Transmission rate: 125Mbps
CONSOLE interface	Physical interface: shielded RJ-45 Interface standard: in line with RS232 standard (3 lines) Interface rate: 9600bps
Power supply	Input voltage: double channelDC24V (DC 18V ~ 36V) Input power consumption: <6W



	Overcurrent protection: built-in
Mechanical parameter	Physical dimensions (height×width×depth): 142 mm×55.4 mm×120.5 mm (excluding the dimensions of DIN rail and wall-mounting components) Mounting mode: DIN rail or wall-mounting Heat removal method: Ribbed aluminum casing heat dissipation without fan. Outlet type: front outlet for service, top outlet for power supply and network management Shell protection: IP40 Weight: 1 kg
Ambient conditions	Operating temperature: -35°C ~ 75°C Storage temperature: -45°C ~ 85°C Humidity: 10% ~ 95% (non-condensing)

2.2 Service Interface

- 1 . Four 10Base-T/100Base-TX RJ45 ports. Each RJ45 port has self adaptation function, capable of automatically configuring to 10Base-T or 100Base-TX state and automatically working in full duplex or half duplex operation mode. The transmission distance is 100m max.
- 2 . Two pairs of uplink redundant 100Base-FX single mode or multi-mode optical fiber interfaces. The maximum throughput of each pair of optical fiber interface is 100Mbps, and it is forced to work in 100M full duplex mode. They support optical fiber line redundancy technology, with the recovery time less than 300ms.
- 3 . Two uplink redundant 10Base-T/100Base-TX RJ45 interface include two kinds of mode. One is straight-through connection mode act as normal Ethernet interface; another one is redundant ring mode and supports twisted-pair redundancy technology with recovery time less than 300ms.
- 4 . In line with/meeting IEEE802.3/802.3U/802.3X.
- 5 . Meanings of RJ45 port indicator: yellow lamp – rate indicator; off: 10M
- 6 . Green lamp – connection state indicator, on: effective connection of network; off: no connection.

2.3 Service function

Configuration and Management

At KIEN6000, the settings, queries and management can be realized for the whole switch or network system through CONSOLE interface.

LED Indicator

The LEDs indicate the port status correctly including transmission rate, link status and system status.

VLAN

The network can be divided into several VLANs according to ports, through which the users in one VLAN can communicate each other. The VLAN of KIEN6000 conforms to IEEE802.1Q and can realize the communication within one VLAN of different switches. KIEN6000 supports up to sixteen VLANs based on IEEE802.1Q.

802.1p Prioritization

KIEN6000 conforms to 802.1p, which is used the most widely in LAN environment. The end-users of KIEN6000 can make use of this function to configure the port-based prioritization when 802.1p is not supported at user's end and different priority is necessary for different ports' services. Only the data package without Prioritization in the Packet in the ports can be affected by this function. Each port of KIEN6000 supports 2 levels (high, low) prioritization.

Layer-2 Switching

Switches work in two ways: Cut-Through and Store-and-Forward. In Cut-Through, a data packet is immediately relayed further after detecting the target address; in Store-and-Forward, a data packet is first read-in completely and checked for errors before the switch relays the same. KIEN6000 employs Store-and-Forward that is a switching mode widely used.

IGMP

IGMP means Internet Group Multicast Protocol. KIEN6000 supports IGMP surveillance and inquiry.

Port Trunking Function

Each logical port has same speed rate, duplex and VLAN ID in KIEN6000.

Setting for Working Mode of Port

KIEN6000 is able to set the working mode of all ports through management: full/half duplex, auto-sensing, enforced full/half duplex, enforced 10M/100M etc.

Broadcast Storm Control



Broadcast storm is the ceaseless transfer of broadcast frame or multicast frame in bridge, which is caused by loop and will waste much bandwidth. The purpose of broadcast storm control is to optimize the performance of switch network. KIEN6000 supports the broadcast storm based on percentage. With the control percentage, the broadcast flow of KIEN6000 will be monitored and controlled effectively. The switch will filter out the over flow and ensure the flow percentage is normal once the bandwidth of broadcast flow exceed the limit.

Alarming

KIEN6000 offers the alarming functions for power, port link and network. Through management software, all the alarming functions can be configured functionally. The alarming information is shown on management interface.

Chapter 3 Hardware Structure

3.1 System structure

The hardware structure of KIEN6000 industrial Ethernet switch is shown in Figure 3-1.

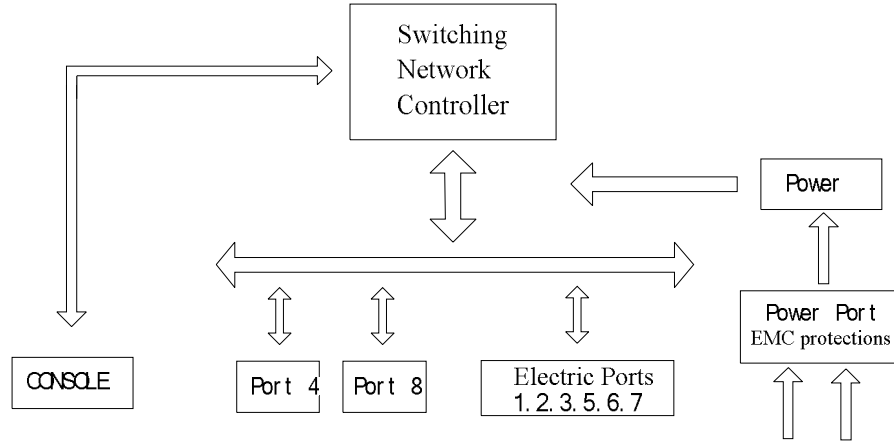

Figure 3-1 Hardware structure

The system hardware mainly consists of:

- 1 . The switch controller employs high-performance ASIC chip technology, and provides two-layer wire speed forwarding of data packet.
- 2 . Optical fiber transceiver module is used for optical fiber interface, offering reliable performance.
- 3 . Industrial power supply with overcurrent, overvoltage and EMC protection.
- 4 . EMC protection is provided for all TP ports and CONSOLE interface.

3.2 Switch Structure

3.2.1 Case

KIEN6000 case is a small DIN rail or wall mounting type structure. The entire unit has a six-side-enclosed structure, with protection class up to IP40. The case's left and right side plates made of ribbed aluminum profile are a part of the heat dispersion system of the entire unit. The single-rib structure can double heat dissipation area. The heat

generated when the unit is working is effectively dissipated into the environment via the ribbed heat-dissipation surface in the form of radiation and convection greatly increasing the high temperature resistance of equipment. Discarding the traditional form of axial fan heat dispersion reduces power consumption of the entire unit and increases the stability of the system. The figuration of KIEN6000 case is shown in Figure 3-2.

Its contour dimension (no including the dimensions of DIN rail and wall-mounting components) is 142 mm×55.4 mm×120.5 mm (height×width×thickness)

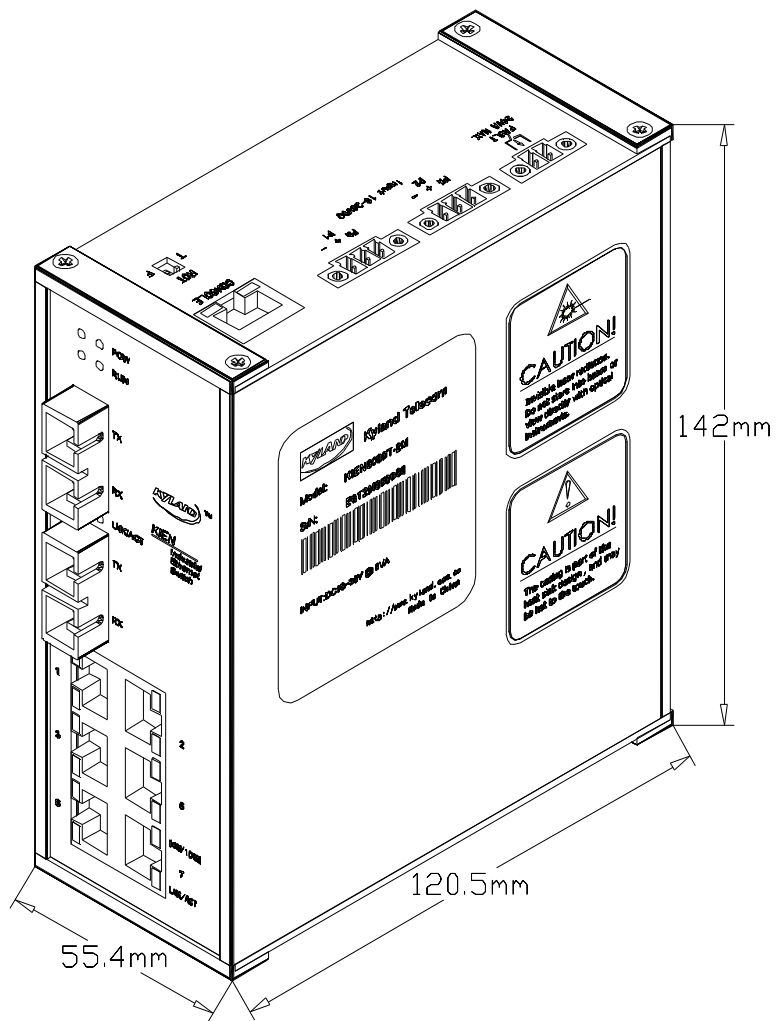

Figure 3-2 Outline drawing of KIEN6000



Warning:

The shell of this switch is a part of the heat dissipation system of the unit. It may get hot during working, so never touch the shell when the equipment is working to avoid burning.

3.2.2 Front panel

The front panel of KIEN6000 industrial Ethernet switch has integrated two pairs of uplink redundant optical fiber interfaces, six uplink redundant 10Base-T/100Base-TX Ethernet RJ45 interface (2 redundant) and six system and port operation indicators. Its structure is shown as Figure 3-3:

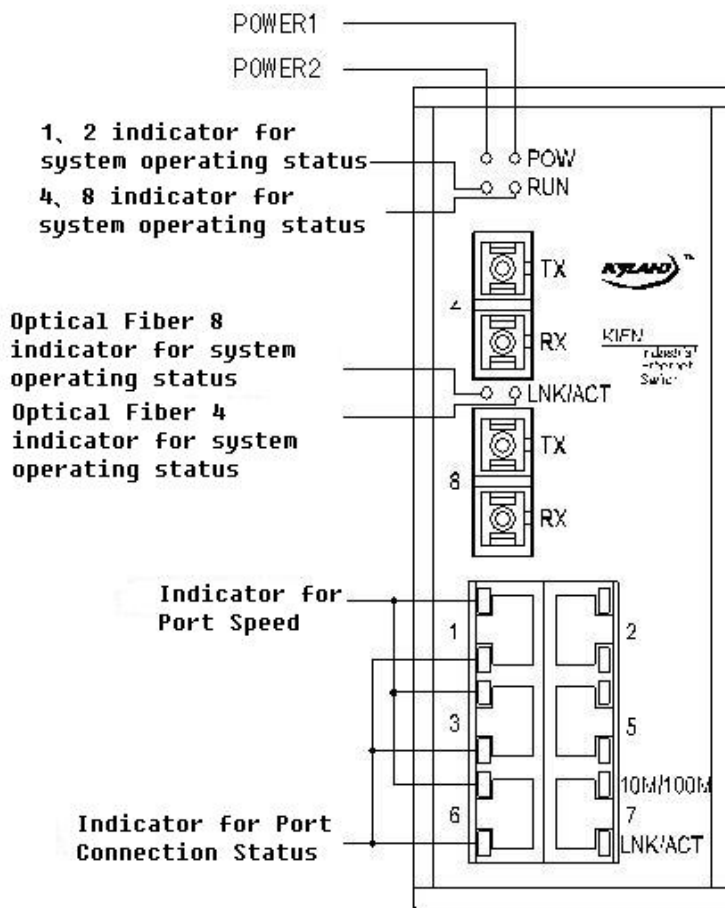

Figure 3-3 Front panel diagram

Optical fiber interface

KIEN6000 offers two pairs of uplink redundant 100Base-FX full duplex single mode or multi-mode optical fiber interface, with port number of 4 and 8 and SC or FC connector. Optical fiber interface should be used in pairs (TX and RX are a pair), TX interface is the transmitting end connected to the receiving end RX of the optical fiber interface of another remote switch; RX is the receiving end connected to the transmitting end TX of the same optical fiber interface of the same remote switch. Two pairs of redundant 100Base-FX optical fiber interface can be used to form an optical fiber redundant ring network. In the event of the system fault, the recovery time of the redundant ring network is less than 300ms, effectively increasing the reliability of network operation.

Uplink redundant Ethernet RJ45 port

KIEN6000 offer two uplink redundant 10Base-T/100Base-TX Ethernet RJ45 ports with port number of 1 and 2, each port has self-adaptation function. Two uplink redundant 10Base-T/100Base-TX Ethernet RJ45 ports can be set as either straight-through mode or redundant ring mode. Straight-through mode act as normal Ethernet Interface, redundant ring mode supports twisted-pair redundancy technology less than 300ms.

RJ45 Ethernet

KIEN6000 offers four 10Base-T/100Base-TX RJ45 Ethernet ports numbering 3, 5, 6, 7. Each RJ45 port has self-adaptation function and can be connected to end equipments, servers, hubs or other switches in straight-through or cross-over way. Each port supports IEEE802.3x self-adaptation, so the most suitable transmission mode (half duplex or full duplex) and data rate (10 Mbps or 100Mbps) will be automatically selected (the connected equipment should also support this characteristic). If the equipment connected to these port does not support self-adaptation, the ports will be able to send at proper speed but transmission mode is default as half duplex.

LED indicator

The indicators on the front panel of KIEN6000 can show system operation and port status, helping detect and eliminate faults. Table 3-1 describes the meanings

of all indication lights on the front panel.

Table 3-1 LED Indicator Description

LED	Condition	State
System state LED		
4、8RUN	On	The optical fiber interface of the switch is set as redundant mode and the unit is set as remote.
	Blinking	The optical fiber interface of the switch is set as redundant mode and the unit is set as remote. .
	OFF	The optical fiber interface of the switch is set as common direction connection mode.
1、2 RUN	On	The optical fiber interface of the switch is set as redundant mode and the unit is set as remote.
	Blinking	The optical fiber interface of the switch is set as redundant mode and the unit is set as remote. .
	OFF	The optical fiber interface of the switch is set as common direction connection mode.
Power LED		
POWER1	On	POWER 1 is connected and operates normally.
	Off	POWER 1 is not connected or operates abnormally.
POWER2	On	POWER 2 is connected and operates normally.
	Off	POWER 2 is not connected or operates abnormally.
Optical fiber interface state LED (optical fiber interface 4, 8)		
LINK/ACT	On	Effective network connection has been established for the port.
	Blinking	Network activities are available for the port.
	Off	No effective network connection has been established for the port.
Ethernet RJ45 port state LED		
Each RJ45 Ethernet port has two indicators, a yellow lamp and a green lamp. The yellow lamp indicates port speed, and the green lamp indicates port link state.		
10M/100M (Yellow)	On	100M working status (i.e. 100Base-TX)
	Off	10M working status (i.e. 10Base-T)
LINK/ACT (Green)	On	Effective network connection has been established for the port
	Blinking	Network activities are available at the port
	Off	No effective network connection has been established for the port.

3.2.3 Top panel

The top panel of KIEN6000 industrial Ethernet has integrates two power input terminals for redundant power supply, alarming relay output terminal, network management port, DIP switch for switch attribute setting etc.

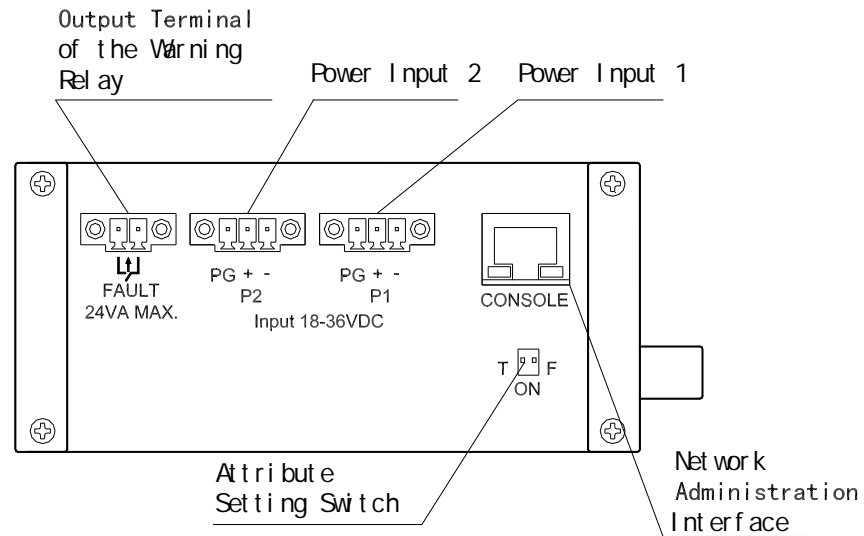

Figure 3-4 Top panel structure diagrams

Power input terminal

KIEN6000 has redundant power input function. It has two power input terminals P1 and P2, each allowed to be used singly, or both to be used simultaneously to input power to KIEN6000 from two independent sets of external DC power supply systems so that when either of the two sets of power supply systems fails, the equipment can operate uninterruptedly, thereby increasing the reliability of network operation. Three-wire terminal with interval of 3.81 mm is used for power connection. The diameter of power cable is less than 1.5 mm.

Connection sequence is shown in Figure 3-5. Connection and mounting procedures are as follows:

- 1 . Strip 5mm-long sheath from power cable and twist the bare copper wires together into a bundle;
- 2 . Use a 2.5 mm one-slot screwdriver to unscrew the “power cable locking screw”, insert the power cable into the hole at the terminal tail, and screw down the “power cable locking screw”;

- 3 . Insert the power terminal into the DC power socket of the equipment and use a 2.5mm one-slot screwdriver to screw down the two “terminal locking screws” to firmly connect the terminal with the power connector.◦

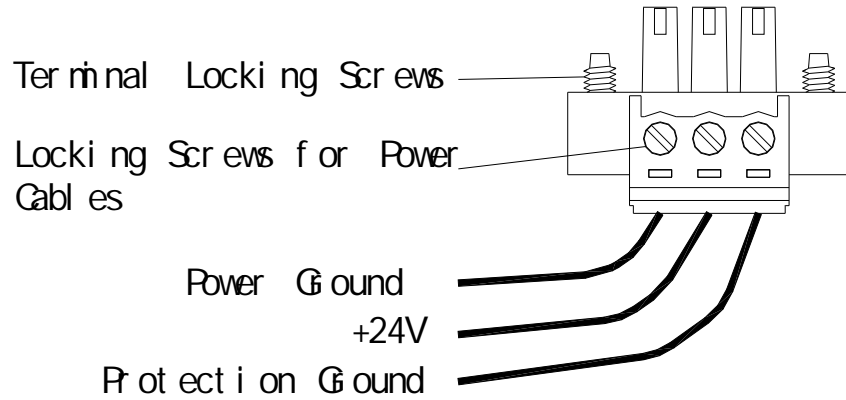

Figure 3-5 Wiring diagram for DC power terminal

Alarming relay output terminal

The terminal is a group of normally open contacts of the alarming relay of equipment. Its figuration is the same as that of power input terminal. Alarming enabling message, such as power failure alarming, port link alarming, network alarming etc., can be set via network management. In normal state without alarming, the terminal is in open state; when any alarming message appears, the terminal is in closed state. It can be externally connected to other switching value collecting equipments or alarming lamps or alarming buzzers so as to timely prompt the operation personnel in case alarming occurs. The maximum withstand voltage of the relay terminal is DC30V and the maximum input power 24VA. Figure 3-6 is the schematic diagram of the equipment when it is connected an alarming indicator and the wiring method for other applications is similar.

Its wiring and mounting procedures are the same as those of power terminal.

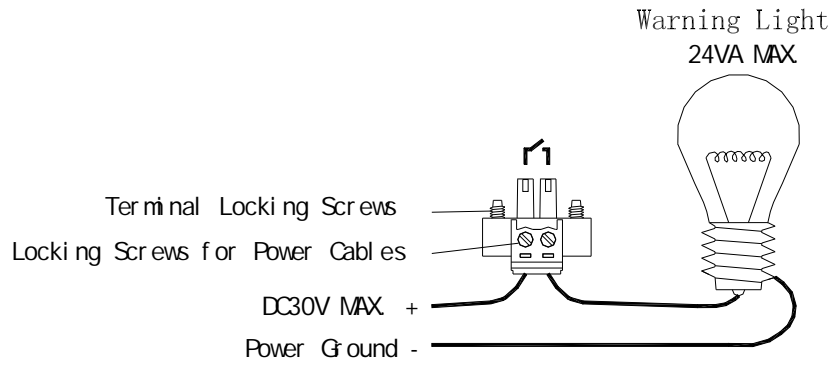

Figure 3-6 External alarming lamp of alarming relay output

Network management interface (CONSOLE)

The network management interface of KIEN6000 is shielded RJ45 connector and its interface communication standard is 3-wire RS232. Users can use a network management cable with end bearing RJ plug and another end DB9F plug to connect the network management interface of KIEN6000 with the 9-pin serial port of the control computer. Operating the local management software provided by KYLAND Telecom in the control computer allows configuration, enquiry and management of the KIEN6000 equipment directly connected with the serial port of the control computer. Connection of network management cable with the local terminal network management interface to operate the network management software provided by KYLAND Telecom in the control computer allows to realize the configuration, enquiry and management functions of all KIEN6000 equipments within the entire network. The wiring sequence for network management interface of KIEN6000 and the 9-pin serial port of PC computer is shown in Figure 3-7.

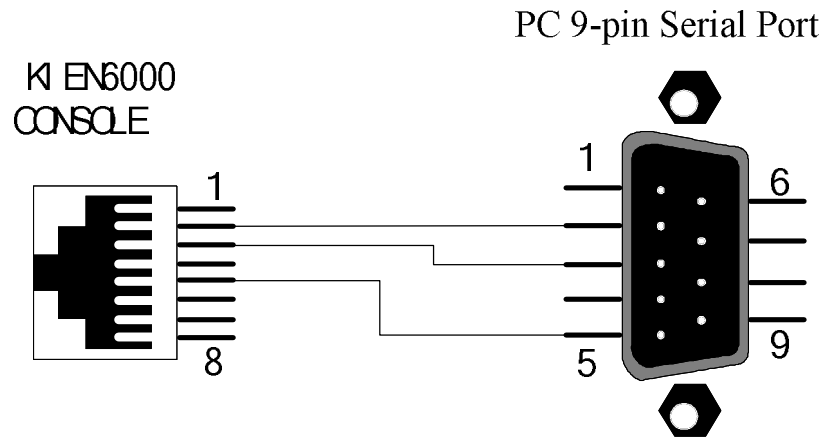





Figure 3-7 KIEN6000 network management wiring diagram

DIP switch for property setting

The DIP switch for setting of KIEN6000 has two positions, namely T and F. T is used for setting redundant mode and common straight-through connection mode of the two pairs of optical fiber interface. If position T shifts to ON, the two pairs of optical fiber interface are set to common straight-through connection mode, otherwise, they are set to redundant mode. F is used for setting the equipment to local or remote when the optical fiber interface is in redundant mode. If T is in OFF, when F shifts to ON, the equipment is set as local, otherwise it is set as remote. The corresponding relation between specific positions of DIP switch and equipment setting is shown in Table 3-2.

Table 3-2 Corresponding Relations between Specific Positions of DIP Switch and Equipment Attribute

Position of DIP Switch		Attribute Implication
Position Sketch	Logic position	
	T OFF	4、8 port set as straight-through connection mode.
	F OFF	1、2 port set as common straight-through connection mode.

	T	OFF	4、 8 port set as set as redundant mode remote.
	F	ON	1 、 2 port set as common straight-through connection mode.
	T	ON	4、 8 port set as set as redundant mode remote.
	F	OFF	1、 2 port set as set as redundant mode remote.
	T	ON	4、 8 port set as set as redundant mode remote.
	F	ON	1、 2 port set as set as redundant mode remote.



Attention:

In an optical fiber redundant ring network, only one end equipment should be set as local, and others as remote.

3.2.4 Bottom panel

There is a threaded hole for grounding in the bottom panel of KIEN6000. M3×8 screw and $\Phi 3$ cold pressed terminal for grounding free of charge will be delivered together with the main unit. As shown in Figure 3-8, crimp one end of grounding conductor to the cold pressed terminal and then use the grounding screw to fix it at the grounding hole of the shell; reliably connect the other end of grounding conductor to the ground. The diameter of grounding cable should be less than 2mm.

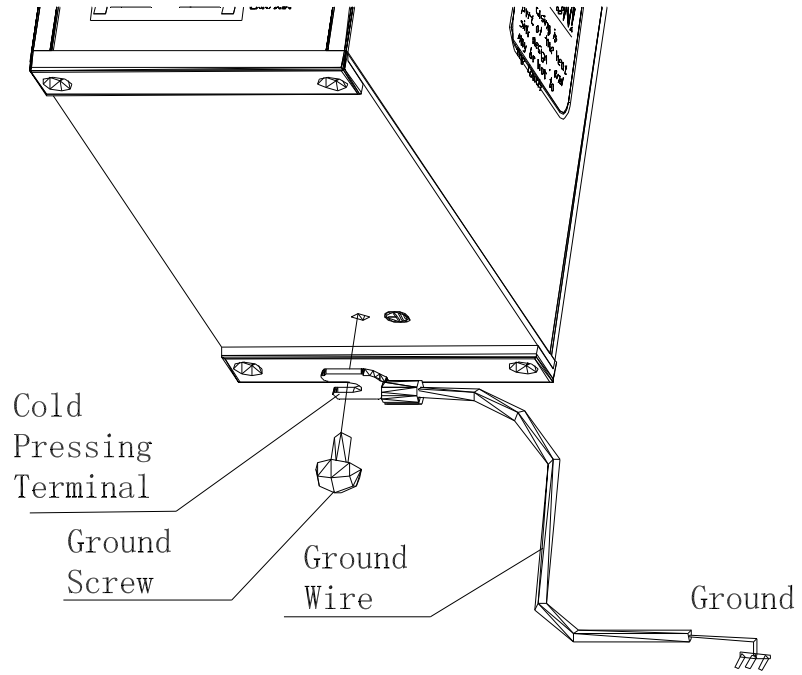

Figure 3-8 Grounding method for KIEN6000 case

Chapter 4 Hardware Mounting

4.1 Mounting requirements

KIEN6000 industrial Ethernet switch has a single body structure and can be directly mounted on standard 35 mm DIN rail, or vertically mounted on the wall or inner wall of cabinet with wall-mounting components.

Before mounting KIEN6000, fire check whether the working environment meets the mounting requirements, including power supply requirement, adequate space, the distance to other network equipments to be connected and whether other equipments are available. Please ensure that the following mounting requirements are met:

- 1 . Power supply requirement: standard KIEN6000 product uses redundant 24VDC power supply (18VDC ~ 36VDC).
- 2 . Environment requirement: temperature $-35^{\circ}\text{C} \sim 75^{\circ}\text{C}$, relative humidity 10% ~ 95% (non-condensable).
- 3 . Grounding resistance requirement: $<5\Omega$
- 4 . Check whether optical fiber cable is laid properly and whether proper optical fiber connectors are used according to the configuration requirements of the contract.
- 5 . Avoid exposure to direct sunlight and keep away from heat source or places with strong electromagnetic interference.
- 6 . Standard KIEN6000 product only provides DIN rail mounting components, so users only need to get DIN rail available. If wall-mounting is necessary, users need to purchase additional wall-mounting components. Moreover, users should also get available screws, nuts and tools for wall mounting and ensure the mounting is reliable.
- 7 . Check whether cables and connectors necessary for mounting are available.

4.2 Main unit mounting

4.2.1 Rail mounting

For most industrial applications, standard 35 mm DIN rail mounting is very convenient. When taken out from the packing box, the rear panel of KIEN6000 has already fitted with a green plastic connector socket for DIN rail. Rail mounting dimensions are shown in Figure 4-1. If it is necessary to mount KIEN6000 on DIN rail, check the mounting conditions of DIN rail before mounting, including the following two items:

1. Whether DIN rail is firmly fixed, whether any other equipment is fitted DIN rail, whether there is adequate space for mounting KIEN6000.
2. Whether there is power inlet on DIN rail suitable for KIEN6000 operation.

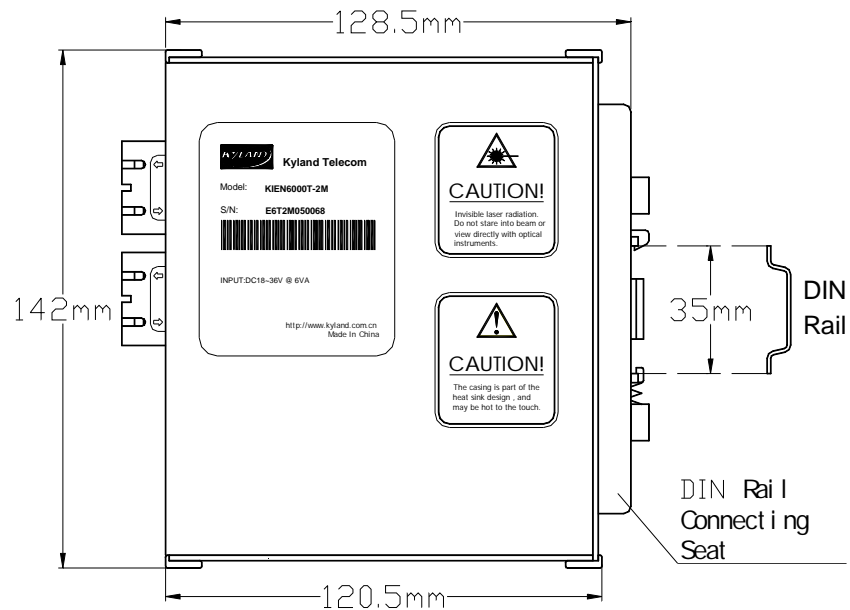

Figure 4-1 Rail mounting dimension of KIEN6000

After selecting the proper position for mounting KIEN6000, mount KIEN6000 on DIN rail according to the following procedures:

1. Insert the lower part of DIN rail into the fixing slot with spring supporting in the lower part of the DIN rail connector socket. Slightly rotate the equipment upwards from bottom panel of KIEN6000 as shown in Figure 4-2 a.

2. As shown in Figure 4-2 b, clip DIN rail into the DIN rail connector socket, and ensure that KIEN6000 equipment has been reliably mounted on DIN rail.

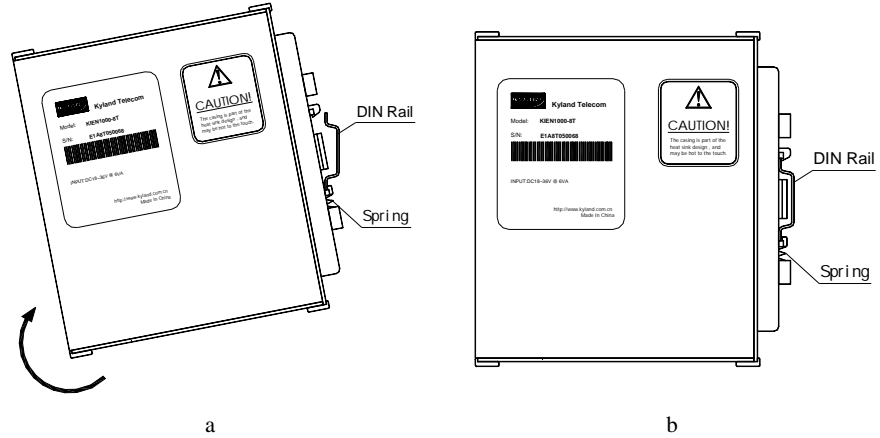

Figure 4-2 Mounting KIEN6000 on DIN rail

4.2.2 Wall-mounting

In some places, wall mounting may be more suitable than DIN rail mounting. KYLAND Telecom can provide the component (wall-mounting plate) for mounting KIEN6000 on wall. Wall-mounting dimensions are shown in Figure 4-3.

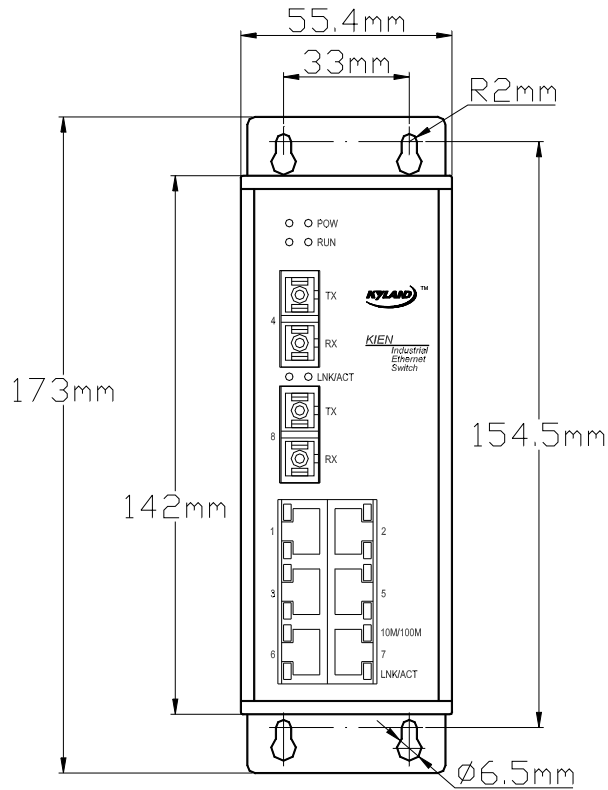

Figure 4-3 KIEN6000 wall-mounting dimensions



Attention:

Wall-mounting plate is not included in standard configuration of KIEN6000. It should be ordered independently when ordering.

Wall-mounting procedures for KIEN6000:

- 1 . Use a cross screwdriver to unscrew the two screws fastening the DIN rail connector socket on KIEN6000 equipment, and remove the green DIN rail connector socket.
- 2 . Take out the wall-mounting plate and the screws (cross recessed countersunk head screws M3×6) for mounting wall-mounting plate from the packing box. Use a cross head screwdriver to mount the wall-mounting plate in the position originally for mounting DIN rail connector socket. The mounting direction of the wall-mounting plate is shown in Figure 4-4.

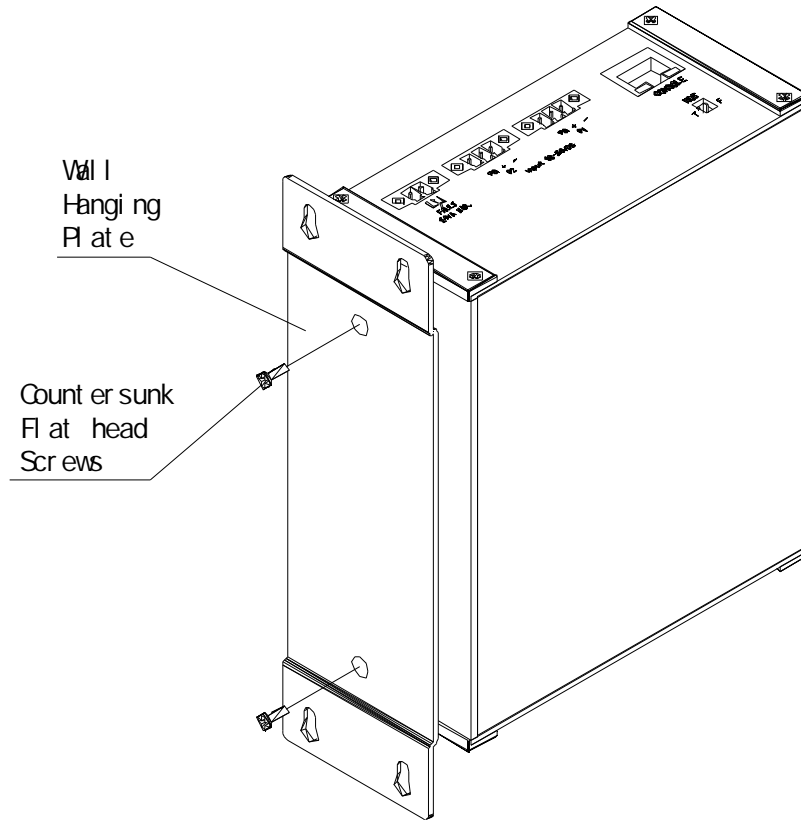

Figure 4-4 Mounting wall-mounting plate

- 3 . Select mounting position: vertical wall or inner wall of cabinet. If you select to mount on vertical wall, you are recommended to use $\Phi 6$ plastic expansion bolts and $\Phi 3$ tapping screws for equipment mounting. According to the mounting dimensions marked in Figure 4-3, drill four $\Phi 6$ holes with an impact drill on the wall (the depth of the holes should allow fully inserting the plastic expansion bolt), fully insert the plastic expansion bolts in the holes on the wall, screw down the tapping screws into the plastic expansion bolts with a cross head screwdriver but do not screw down thoroughly, reserve a distance of around 5 mm; if you select to mount on the inner wall of cabinet, you are recommended to prepare four M3 threaded holes on the inner wall of cabinet when making the cabinet according to the mounting dimensions marked in Figure 4-3, or drill four $\Phi 4$ holes with a hand-held electric drill on site, and screw down four M3 \times 10 pan head screws with cross recess into the four holes with a cross head screwdriver (if the holes are not threaded inside, it is necessary to mount four M3 nuts on the back side). Do not screw down the screws thoroughly, reserve a distance of around 5 mm.

- 4 . After fastening the screws on the wall, mount KIEN6000 in the selected position. Pass the four screws through the four $\Phi 65$ holes on the wall-mounting plate and slip KIEN6000 downwards, as shown in Figure 4-5. Fasten the four screws. KIEN6000 has now been fastened on the wall or inner wall of cabinet.

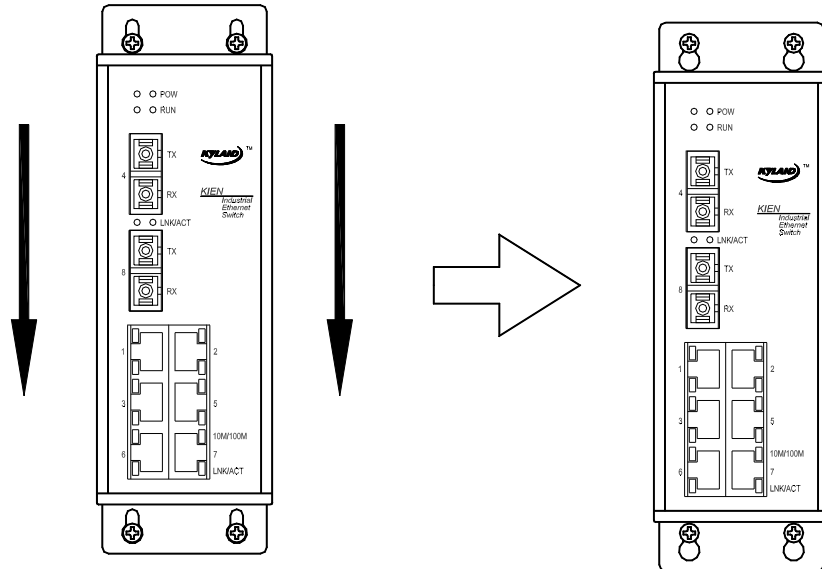

Figure 4-5 Schematic diagram for wall-mounting process

4.3 Cable connection

After properly mounting KIEN6000, it is ready for cable mounting and connection, mainly including cable connection for the following interfaces:

- 1 . Service interface

KIEN6000 provides 10Base-T/100Base-TX RJ45 Ethernet interface for the connection to end equipments in straight-through way and to network equipments in cross-over way.

- 2 . Network management interface connection

KIEN6000 is connected with the serial port of control computer via the CONSOLE port of the top panel. Users can make a network management line with proper length according to Figure 3-7.

- 3 . Power connection

Use 24V DC power supply for KIEN6000 equipment according to the indications on product label. Connect power supply after completing connection for all other cables.

4.4 Optical fiber connection

KIEN6000 provides 2 pairs of redundant 100Base-FX full duplex single mode or multi-mode optical fiber interfaces. These optical fiber interfaces can be used to form an optical fiber redundant ring network. In case an equipment or optical fiber cable at some point fails, the network can recover within 300ms. SC or FC optical fiber interface can be selected according to actual needs.



Warning:

This switch uses laser to transmit signal on optical fiber cable. The laser meets class 1 laser product requirements and harmless to eyes under normal operation. However, when the equipment is switched on, do not stare directly into the optical fiber transmitting interface and the end of optical fiber terminator.

Connect pluggable optical fiber module according to the following procedures:

- 1 . Remove and keep the rubber sleeve of SC or FC port. When it is not in use, cover SC or FC port with the rubber sleeve to protect the optical fiber terminator.
- 2 . Check whether the optical fiber terminator is clean. Slightly wet a clean tissue or cotton ball and carefully wipe cable plugs. Contaminated If the optical fiber terminator is contaminated, transmitting quality of optical fiber will reduce, affecting port performances.
- 3 . Connect one end of optical fiber cable to the optical fiber interface of the switch and the other end to the optical port of another equipment as shown in Figure 4-6.

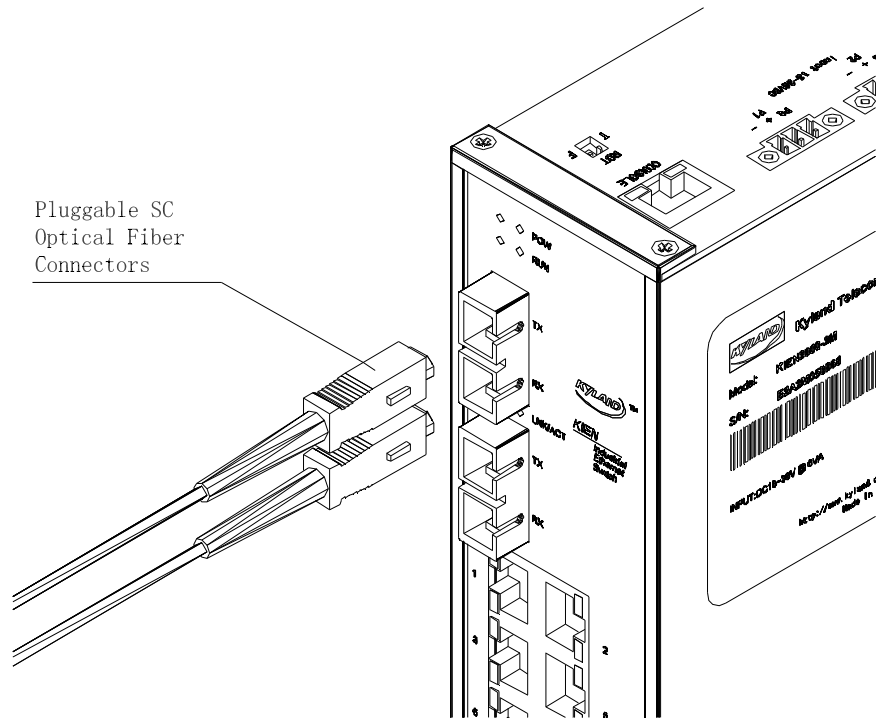

Figure 4-6 Fiber port connection

- 4 . After accomplishing the connection, please check the LNK/ACT indicator on the front panel for the corresponding optical port. If the indicator is on, this means the connection is effective.

4.5 Cable wiring

Cable wiring should meet the following requirements:

- 1 . Before cable wiring, check whether the specifications, models and quantities of all cables comply with the construction drawing design and contract requirements.
- 2 . Before cable wiring, it is necessary to check whether there is damaged cable and whether the cables are accompanied by ex-factory records and vouchers attesting their quality such as quality assurance certificate etc.
- 3 . The specifications, quantities, route directions and laying position of the cables to be laid should meet the design requirements of construction drawings. The

laying length of each cable should be determined according to its actual position.

- 4 . No intermediate break or joint is allowed for the cables to be laid.
- 5 . User's cables and power cable should be laid separately.
- 6 . Inside walkways, the cables should be properly arranged in good order, with uniform, smooth and flat turnings.
- 7 . Cables should be straightly laid in cable channels. Extruding of cable from cable channels to block other outlet or inlet holes is not allowed. The cables at the outlet part of cable channel or at turnings should be bundled and fixed.
- 8 . If cables, power line and grounding conductor are laid in the same channel, cables, power line and grounding conductor should be not folded or blended together. If a cable line is overly long, coil and place it in the middle of the cabling rack, do not let it cover on other cables.
- 9 . When laying the pigtail, avoid knotting of optical fiber cable, minimize the amount of turnings and avoid turnings with overly small radius. Bundle pigtails in proper tightness and avoid too tightly bundling. If laid on a cabling rack, it should be placed separately from other cables.
- 10 . There must be the relevant marks at both ends of cable and the information on the marks should be explicit to facilitate maintenance.



Attention:

When laying pigtails, prevent optical fiber cable from knotting, minimize the amount of turnings and avoid turnings with too small radius, because turning with too small radius will result in serious consumption of optical signal of links, affecting communication quality.

Chapter 5 Testing Method

5.1 Self-testing process

As soon as the equipment is powered, all the indicator of service ports at the front panel will blink once at the moment, this indicates the operation of the ports is normal, after this, the corresponding POW will keep the light on, the RUN lamp (operation lamp) will keep on light/blink/be off according to the attribute of attribute switch setting.

5.2 Testing of Ethernet interface

Power KIEN6000 as shown in Fig. 5-1, make any two Ethernet interfaces connect with the network port of the two testing computers by straight-through network cable, transmit Ping command mutually, both sides can correctly Ping to each other and no data package is lost. At the same time, the yellow lamp on the corresponding port should keep on (computer network interface card operates in 100M state), or keep off (computer network card operates in 10M state), and the green lamp on the corresponding port should flash. This indicates the tested hardware of the two electrical operates normally. The same testing method will be used to test all the rest Ethernet interfaces (For detailed operation of the Ping command, please refer to the following examples).

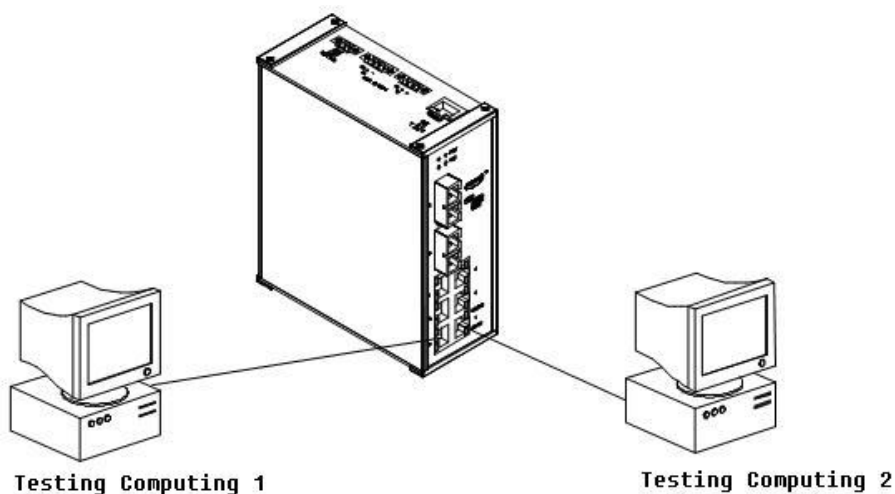

Fig. 5-1 Testing of Ethernet port

5.3 Testing of optical fiber interface

Let the equipment of KIEN6000 at both ends to form a fiber link network as shown in Fig. 5-2., connect any one Ethernet interface of each equipment to the testing computer by straight-through network cable, transmit Ping command mutually, both sides can correctly Ping to each other and no data package is lost. At the same time, the LINK/ACT lamp of the corresponding optical port should light. This indicates the tested hardware of the two electrical operates normally. The same testing method will be used to test the other pair of optical ports (For detailed operation of the Ping command, please refer to the following examples).

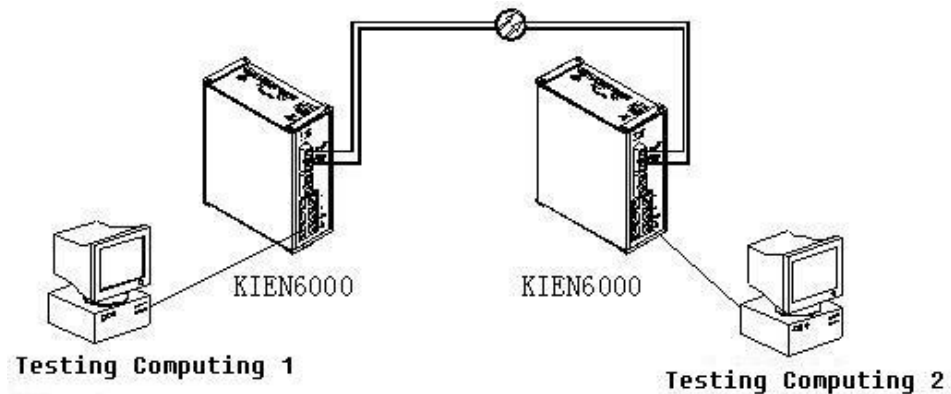

Figure 5-2 Optical port testing

Example of PING command:

The IP address of testing computer 1 is 192.168.100.10, and that of the testing computer 2 is 192.168.100.11 , operating command in the “Operation” column of the “Starting” menu of the operating testing computer 1 is cmd or command (WIN2000 system uses cmd, WIN98/95 uses command respectively), transmitting ping is 192.168.100.11 -l 1000 -t (-l refers to the number of byte, -t means continuously transmitting data), operating command in the “Operation” column of the “Starting” menu of the operating testing computer 2 is cmd or command (WIN2000 system uses cmd, WIN98/95 uses command respectively), transmitting ping is 192.168.100.10 -l 1000 -t , testing computer 1 replies from 192.168.100.11 : bytes=1000 time<10ms TTL=128, testing computer 2 replies from 192.168.100.10 : bytes=1000 time<10ms TTL=128. If the lost package rate is 0 based on the statistic by using CTL+C command after the operation is over 10 minutes, this indicates that the operation is normal.

Chapter 6 Networking Mode and System Configuration

6.1 Networking mode

KIEN6000 Industrial Ethernet Switch has 4 10Base-T/100Base-TX RJ45 Ethernet ports, each can provide special link to end equipment directly, or connect another industrial Ethernet switch or hub as a common link. KIEN6000 Industrial Ethernet Switch also has two pairs of 100Base-FX single-mode or multi-mode optical fiber interfaces of uplink redundancy. By using the uplink redundancy optical fiber interface, an optical fiber redundant ring network can be formed. The recovery time of the ring network redundancy is less than 300ms when the system is in fault. It is widely applied in many fields, such as electric power, transportation, energy, water treatment, automatic control of large factory and office scheduling etc.

The most typical network- forming mode of KIEN6000 is redundant ring network and redundant double ring network. KIEN6000 can form an optical fiber redundant ring network as shown in Figure 6-1, in which one end unit is set as local one, and the others as remote one. When a fiber disconnection happens at any place, communication can be resumed within 300ms.

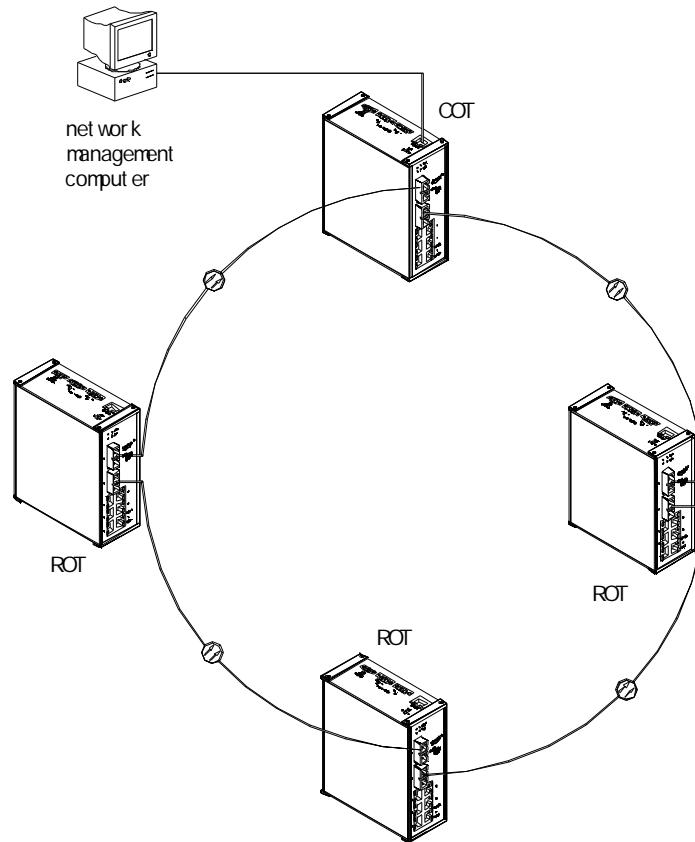

Figure 6-1 Optical fiber redundant ring network composed by KIEN6000

KIEN6000 can form an optical fiber redundant double ring network as shown in Figure 6-2. When a fiber disconnection happens at any place, communication can be resumed within 300ms.

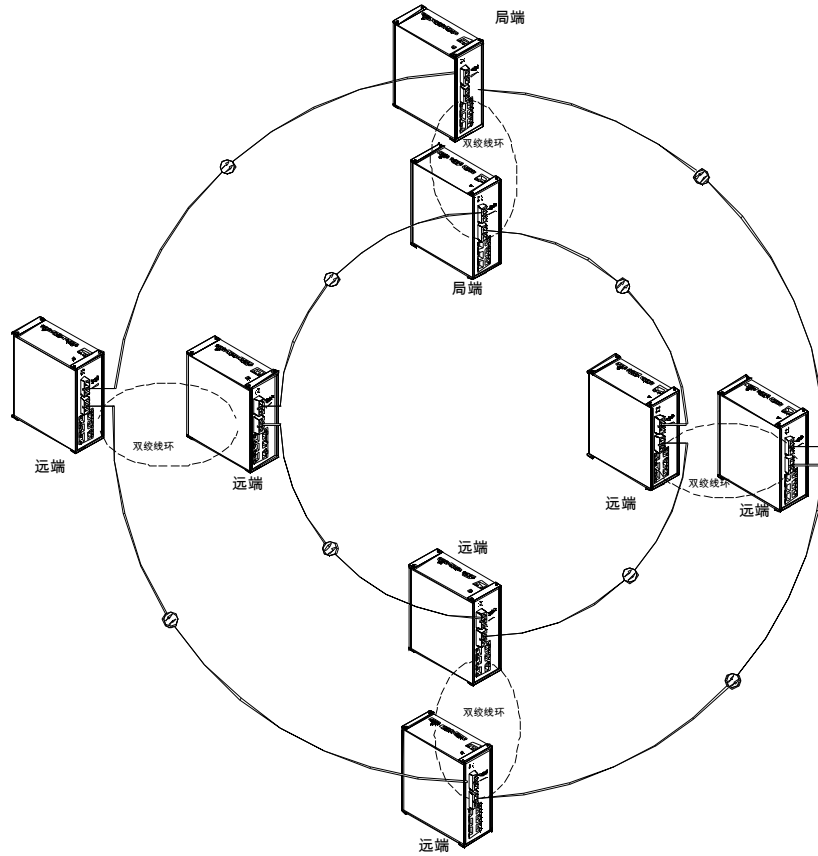
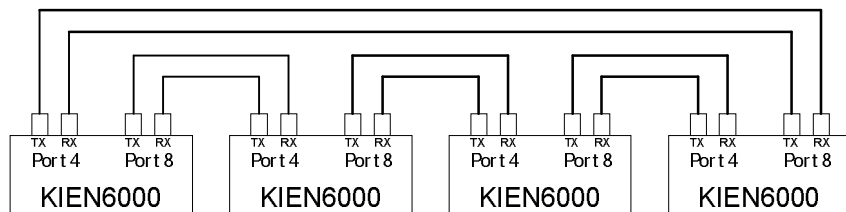

Figure 6-2 Optical fiber redundant double ring network composed by KIEN6000



Attention:

When KIEN6000 is forming a redundant ring network, connection of optical port 4 and 8 are recommended, namely, the optical port 4 of one end equipment shall be connected with the optical port 8 of the other end equipment. This is shown as the following figure.





6.2 System configuration

KIEN6000 Industrial Ethernet Switch is an integrated structure; the 6 10Base-T/100Base-TX Ethernet RJ-45 ports and 2 pairs of uplink redundant 100Base-FX/100Base-FX optical fiber interfaces are with fixed configuration. The fiber port can be single-mode or multi-mode. The power supply voltage is DC 24V. The specific configuration and its corresponding models are shown as Table 6-1.

Table 6-1 Configuration table of KIEN6000

Product Model	Product Description
KIEN6000-2S	2 pairs of uplink redundant 100Base-FX single-mode optical fiber interface
KIEN6000-2M	2 pairs of uplink redundant 100Base-FX multi-mode optical fiber interface

Appendix A Twisted-pair and Pin Distribution

For the connection of 10Base-T/100Base-TX, the twisted-pair must have two pair cable. Each pair is distinguished with two different colors. For example, one strand is green, and the other is the alternate of green and white stripes. RJ-45 connector should be equipped at both ends of the cable.



Warning:

Don't insert a telephone plug into any RJ-45 port. Only use twisted-pair with RJ45 connectors at both ends conforming to FCC standard.

Fig. A-1 Shows how the connector of RJ-45 is numbered please make sure that the inserting direction is correct.

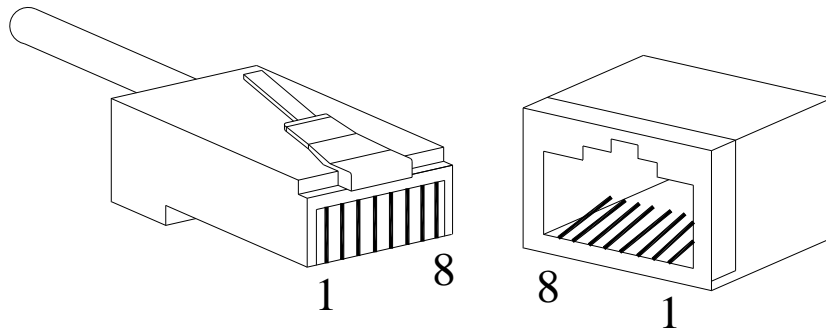

Figure A-1 Connector of RJ-45

Pin distribution of 10Base-T/100Base-TX

Unshielded twisted-pair (UTP) or shielded twisted-pair (STP) will be used for the connection of RJ-45: for the connection of 10Mbps, category 3, 4 and 5 of 100 ohm will be used, and cat.5 of 100 ohm will be used for 100Mbps. Additionally, do make sure that the connecting length of any twisted-pair shall not exceed 100 meter.

Port of RJ-45 supports automatic MDI/MDI-X operation, PC or server may be connected with straight-through cable, or connect with other switch or

hub. In straight-through cable, pin 1, 2, 3 and 6 at one end of the cable are connected to pin 1, 2, 3 and 6 at the other end of the straight-through cable respectively. Cross-over cable must be used for switch or hub with MDI-X port. The pin distribution of 10Base-T/100Base-TX is listed in the table A-1.

Table A-1 Pin distribution of 10Base-T/100Base-TX

Pin	MDI-X signal name	MDI signal name
1	Receiving data + (RD+)	Output data + (TD+)
2	Receiving data - (RD-)	Output data - (TD-)
3	Output data + (TD+)	Receiving data + (RD+)
6	Output data - (TD-)	Receiving data - (RD-)
4 , 5 , 7 , 8	Unused	Unused

Note: "+" "-"denoting cable polarity.

Definition of straight-through cable from RJ45 (8-pin) to RJ45 (8-pin)

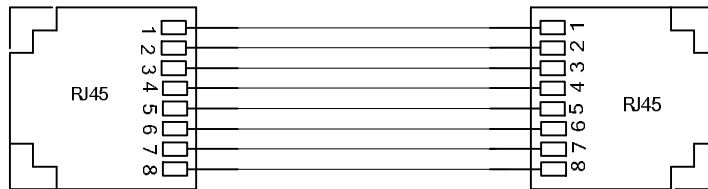

The connection sequence is in turn: Orange-white, Orange, Green-white, Blue, Blue-white, Green, Brown-white and Brown

Figure A-2 Cable sequence of straight-through cable

Definition of Cross-over cable from RJ45 (8-pin) to RJ45 (8-pin)

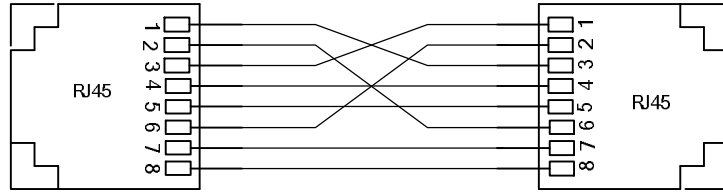

The connection sequence is in turn: Orange-white, Orange, Green-white, Blue, Blue-white, Green, Brown-white and Brown
Green-white, Green, Orange-white, Blue, Blue-white, Orange, Brown-white and Brown

Figure A-3 Cable sequence of cross-over cable

Appendix B Cable Type and Specifications

The cable type and specifications are shown as table B-1:

Table B-1 Cable type and specifications

Cable	Type	Max. length	Connector
10Base-T	Cat.3, 4 and 5 100 ohm UTP	100m (328 foot)	RJ-45
100Base-TX	Cat.5 –100 ohm UTP	100m (328 foot)	RJ-45
100Base-FX	50/125 or 62.5/125 μ m core multi-mode fiber (MMF)	2km (1.24 mile)	SC/FC
100Base-FX	9/125 μ m core single -mode fiber (SMF)	20km (12.43 mile)	SC/FC

Appendix C Glossary

Terminology	Explanation
10Base-T	Twisted-pair standard of Cat3, Cat4 and Cat5 in IEEE specification for 10Mbps Ethernet
100Base-TX	Twisted-pair standard of Cat5 or above in IEEE specification for 100Mbps Fast Ethernet
100Base-F X	Fast Ethernet which uses one pair of multi-mode or single mode optical fiber to transmit.
Adaptive	A characteristic that is automatically configured to adaptive mode for the speed, duplex and traffic control port.
Bandwidth	The information capacity that the channel can transmit. For instance, the bandwidth of the Fast Ethernet is 100Mbps (bit per second) .
Baud Rate	It expresses the signaling rate which is defined as the change times of the status for the electric or optical transmission medium within 1 second.
Bridge	One of network equipments which run on the layer2 in the OSI layer7 model, and it can be connected to the LAN or network segment which uses the same protocol. It presents the automatic network address learning and network configuration function.
Traffic Control	It is a congestion control mechanism. The network equipment sends the data to the equipment which has overloaded and causes the port to congest. The traffic control can prevent the data packet from loss and avoid the congestion for the port.
VLAN	It is the Virtual Local Area Network, which means that it takes the network management software to establish the point to point logic network which can cross different network segment and various network on the switching LAN.
Broadcast	One data packet is sent to all equipments on the network.
Broadcast storm	Restless forward broadcast frame or multicast frame on bridge caused by the bridge ring.
IGMP	IGMP means Internet Group Multicast Protocol.
Full Duplex	Use switches to set up the point to point connection among nodes in the LAN and allow them to receive and send data packet at the same time.
Half Duplex	The communication for two nodes can only move toward one direction at the same time, but can not move toward both directions.
MDI	It is the Medium Dependent Interface, in which, one Ethernet port is taken as the receiving terminal to connect to the port of other equipment.
MDI-X	Medium Dependent Interface Cross-over

